

BRUSHED NICKEL, MATTE WHITE ACRYLIC

CEILING MOUNT LAMP

CG14E26-BN	
Dimension	Dia. 14in X H3.54in
Material	Steel, Acrylic
Finishes	Brushed Nickel, Matte White Acrylic
Bulb Types	E26x2pc(13W Max)
Standards	UL-CUL Listed

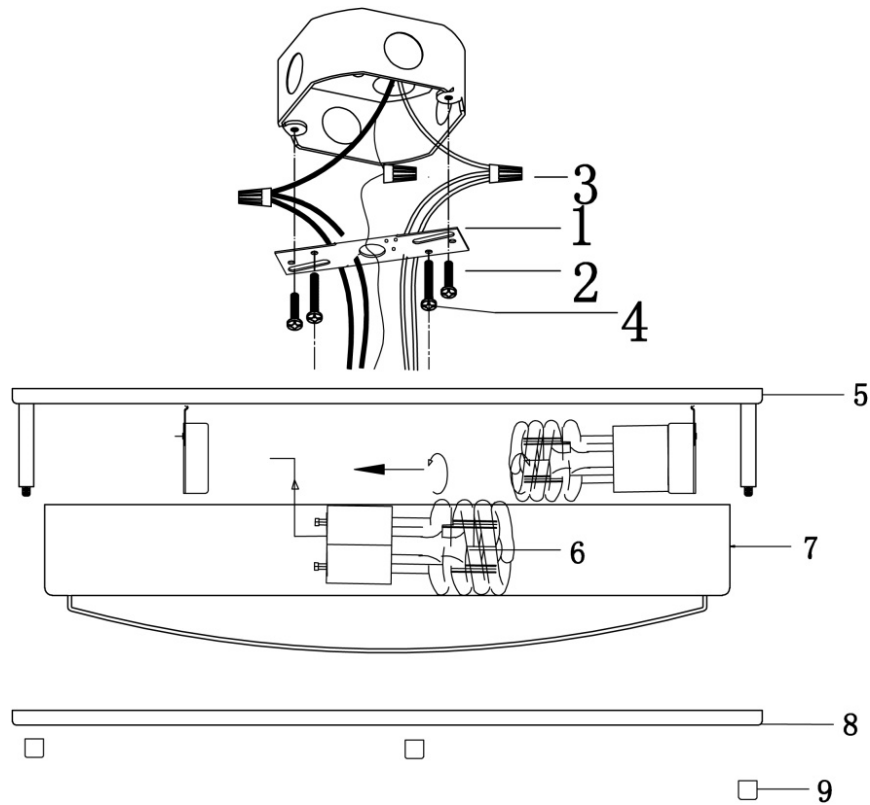

URBN Building Products, LLC

110-110th Avenue NE, Suite 550, Bellevue, WA 98004 USA

Phone: (800) 866-3646 – E-mail: info@URBNBP.com